



Year 5/6

Topic

Week 4

Date		
Subject/s	D&T/History	
Learning Objective	I can create a 3D model	
	SA	TA
		
Success Criteria	I can use a map of Eyam to plan out my	
	I can make 3D buildings from nets	
	I understand how the lay out of Eyam helped	
Support	Independent	Adult Support ( )

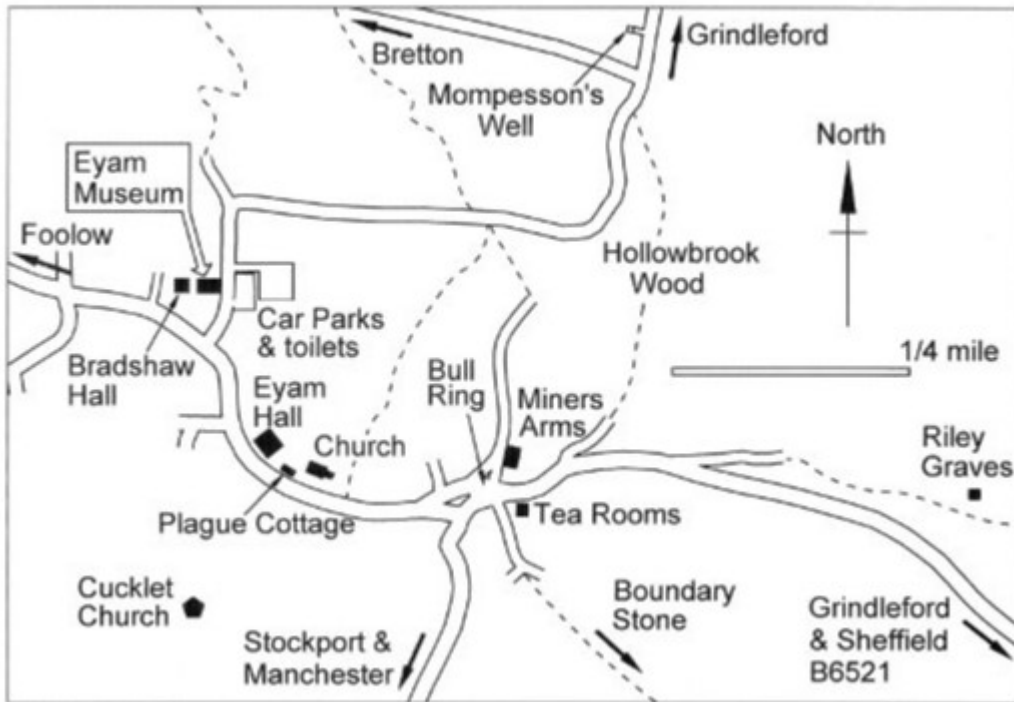

Look at the village of Eyam using google maps and the map above. What do you notice about the houses?

Use the 3D nets to create your own model village of Eyam.

1. Cut out the triangular prism nets and decorate them to look like the roof.

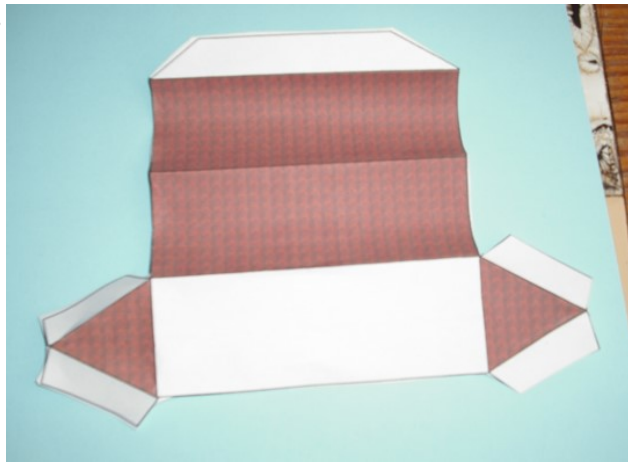

2. Cut out the cuboid nets and decorate to make the walls of the buildings.



3. Stick the nets together to make a building.





4. Use a piece of paper to plan out your model village. Stick your buildings where you would like them and label them.

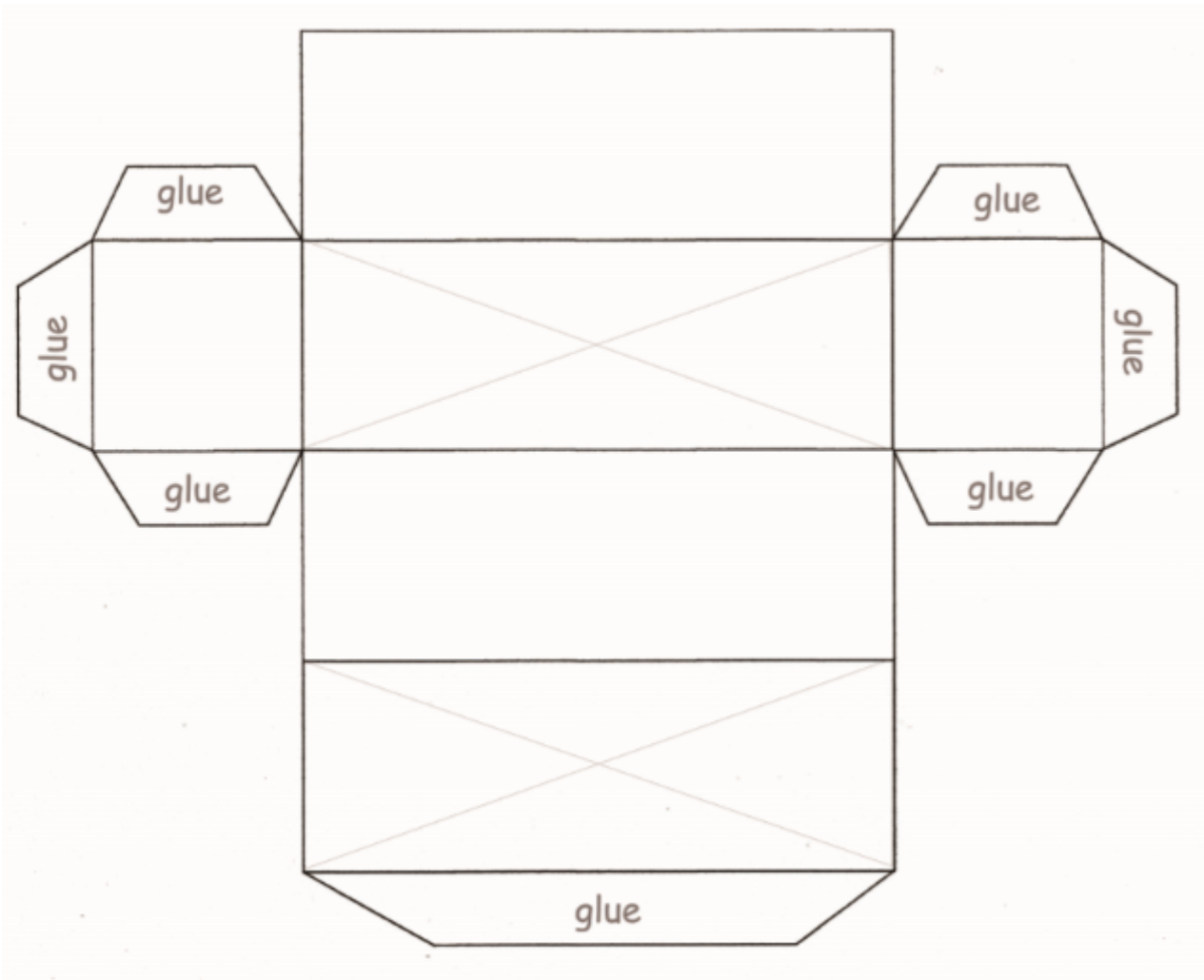
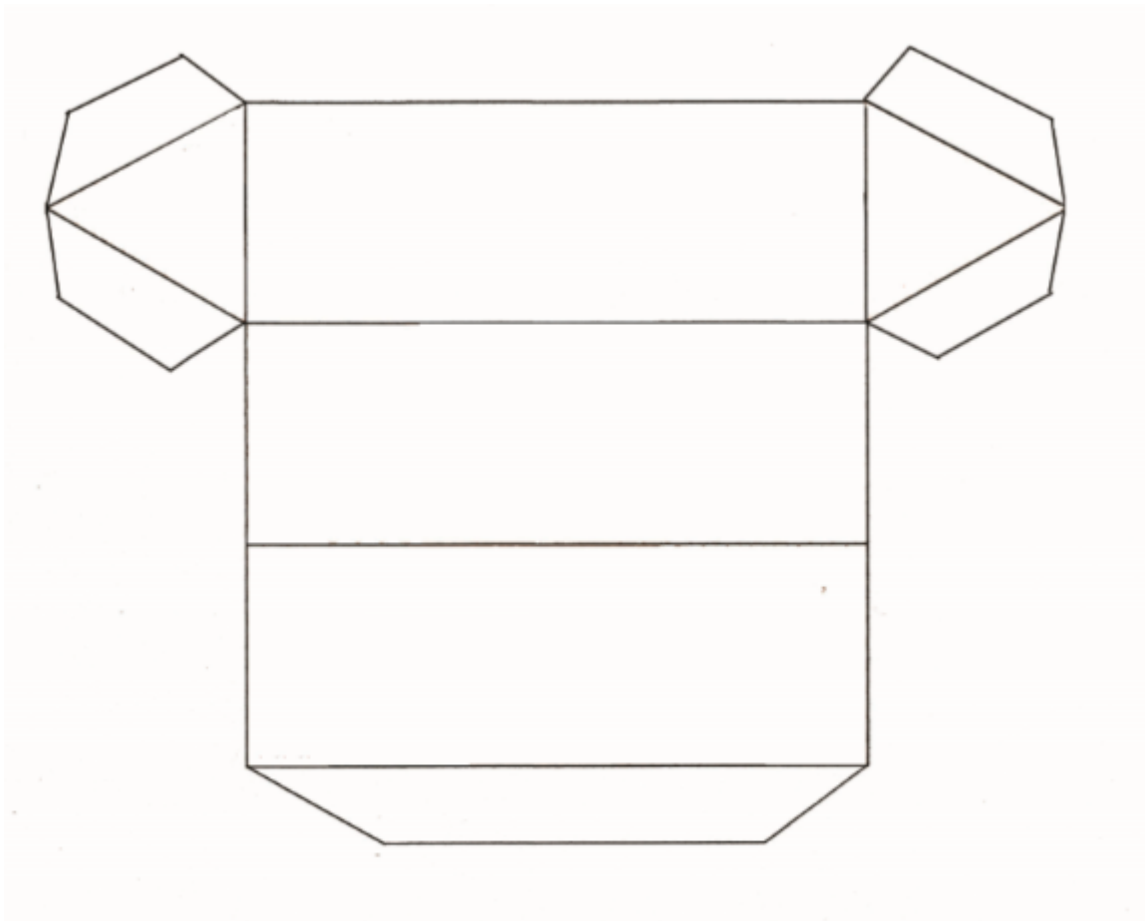

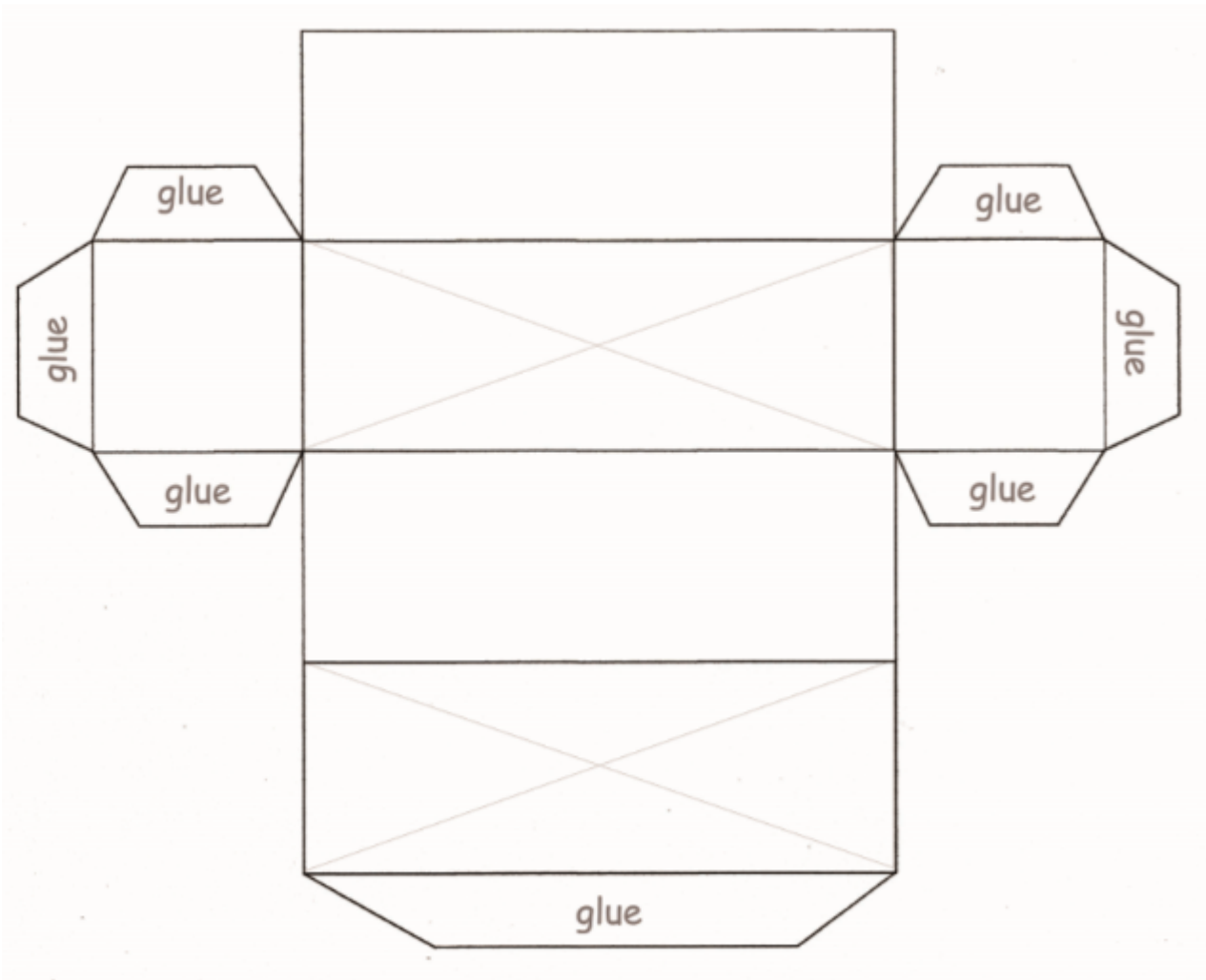
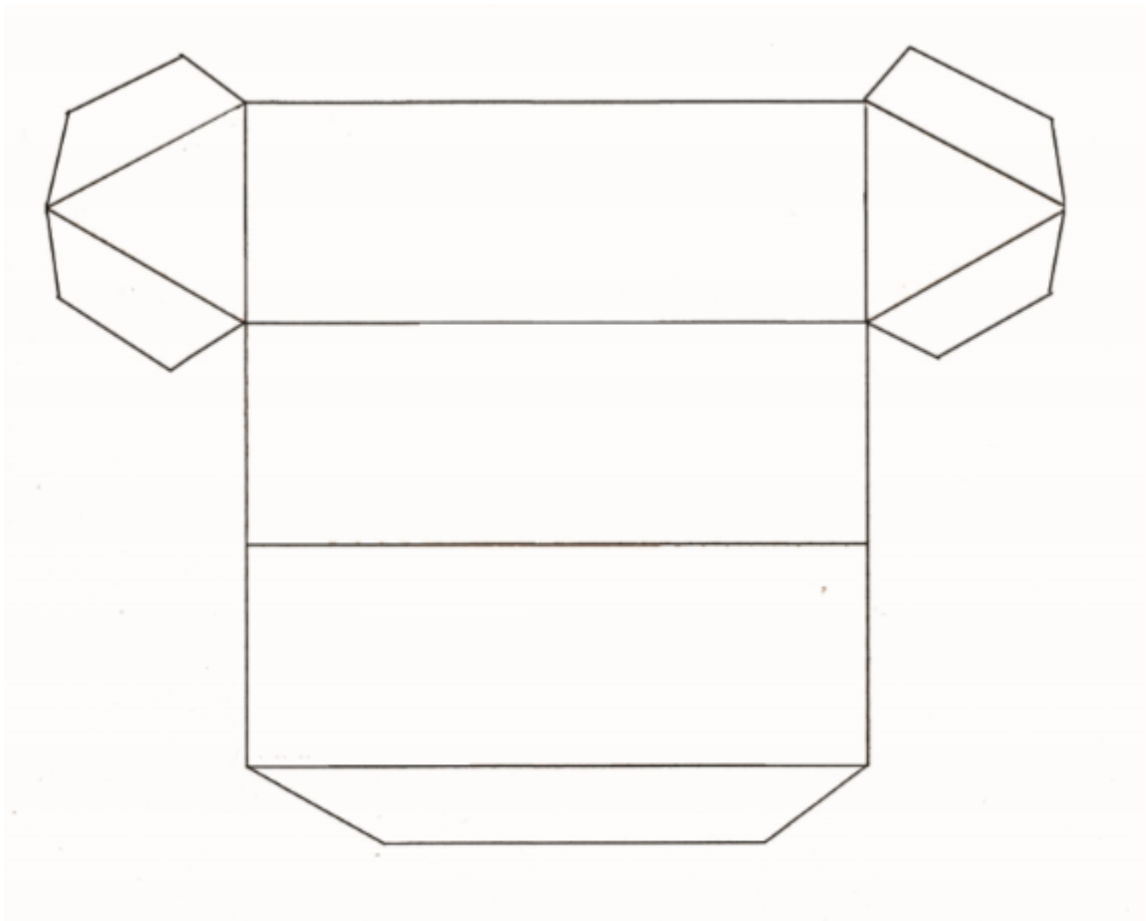

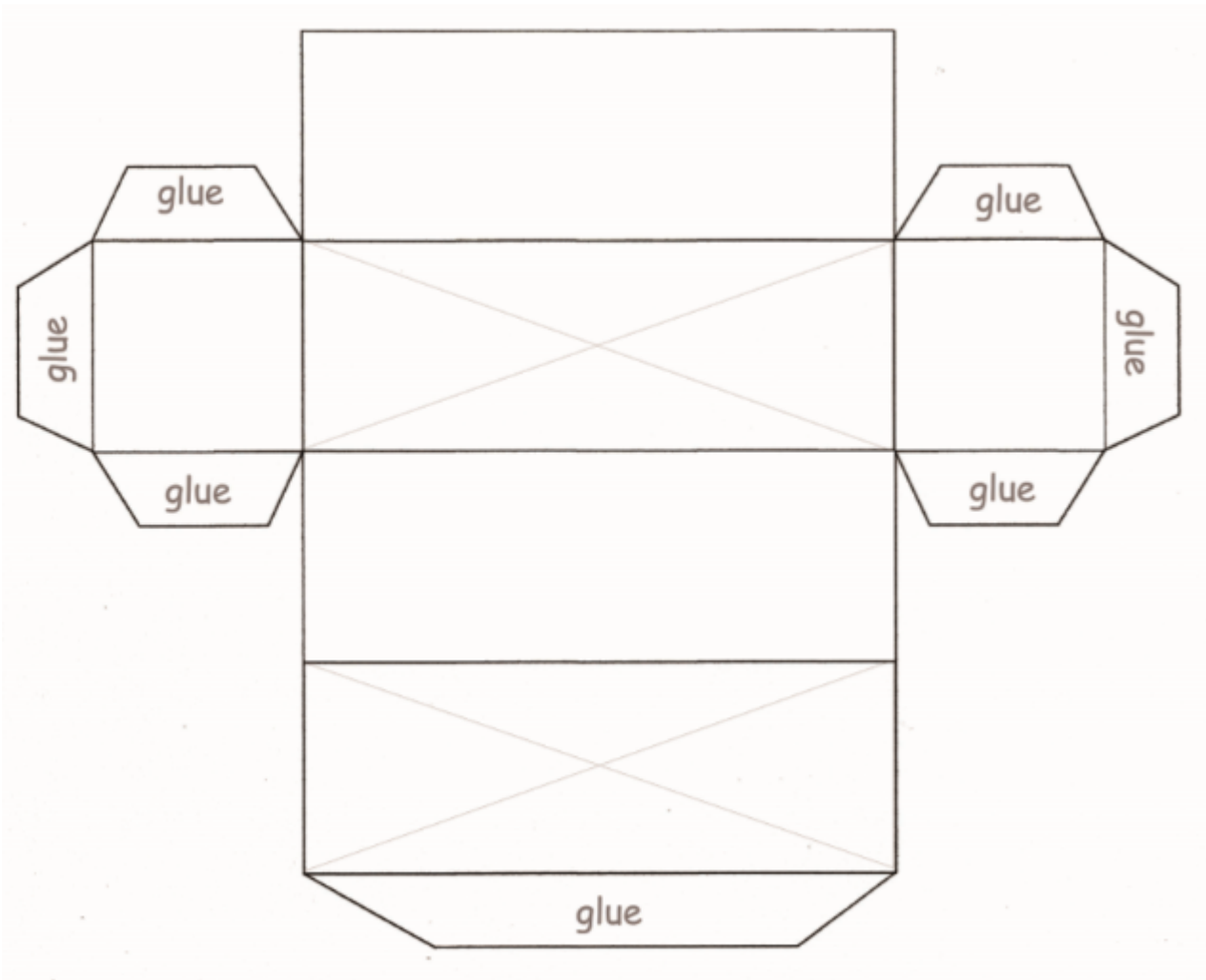
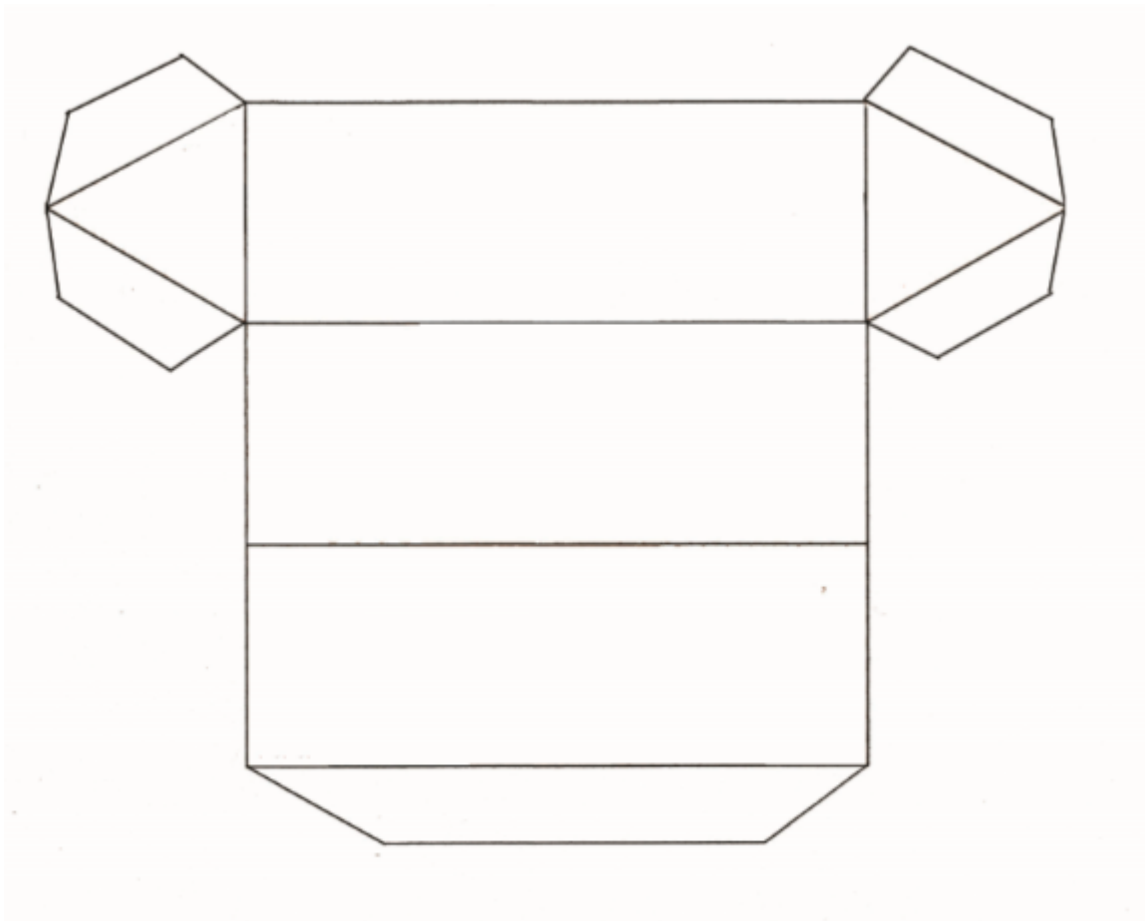

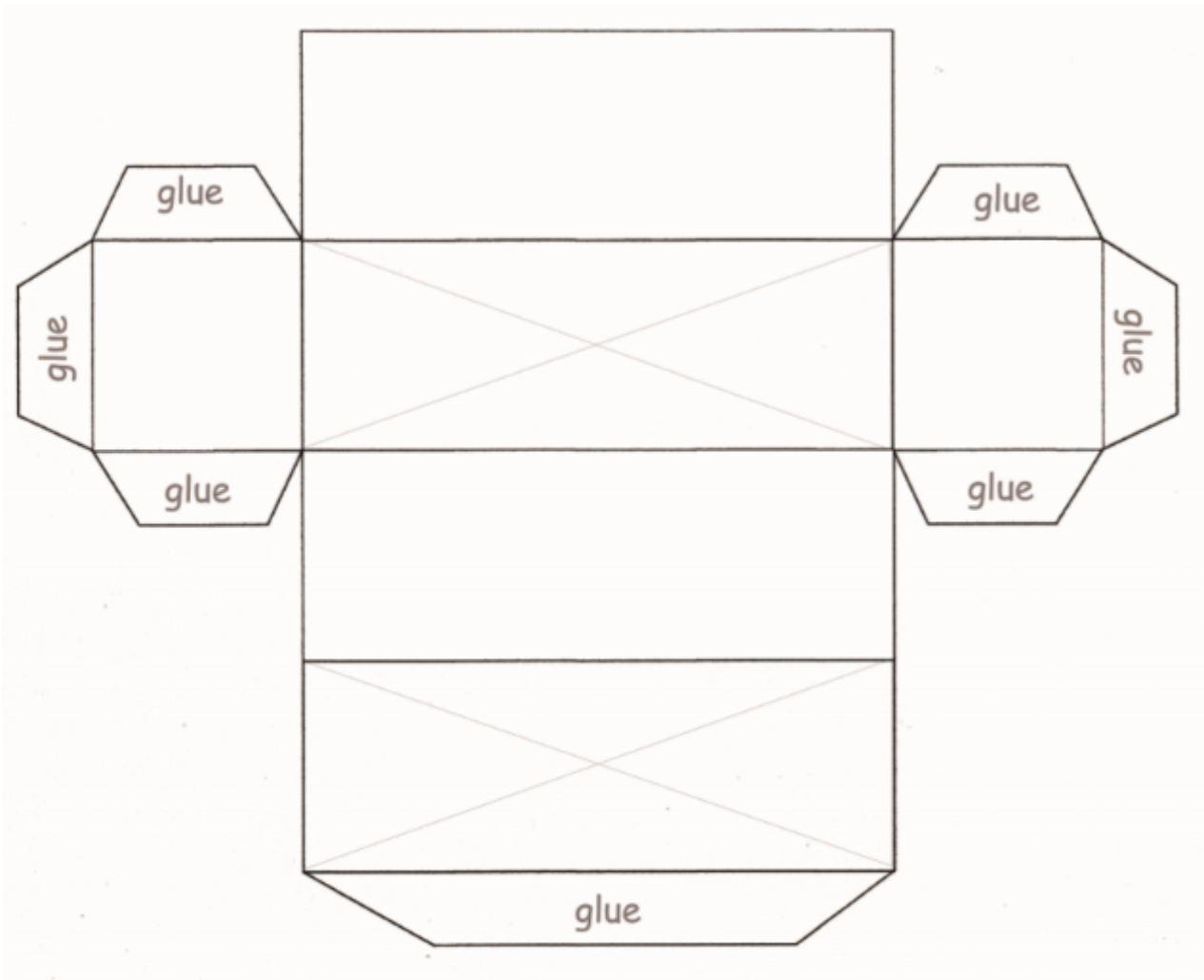
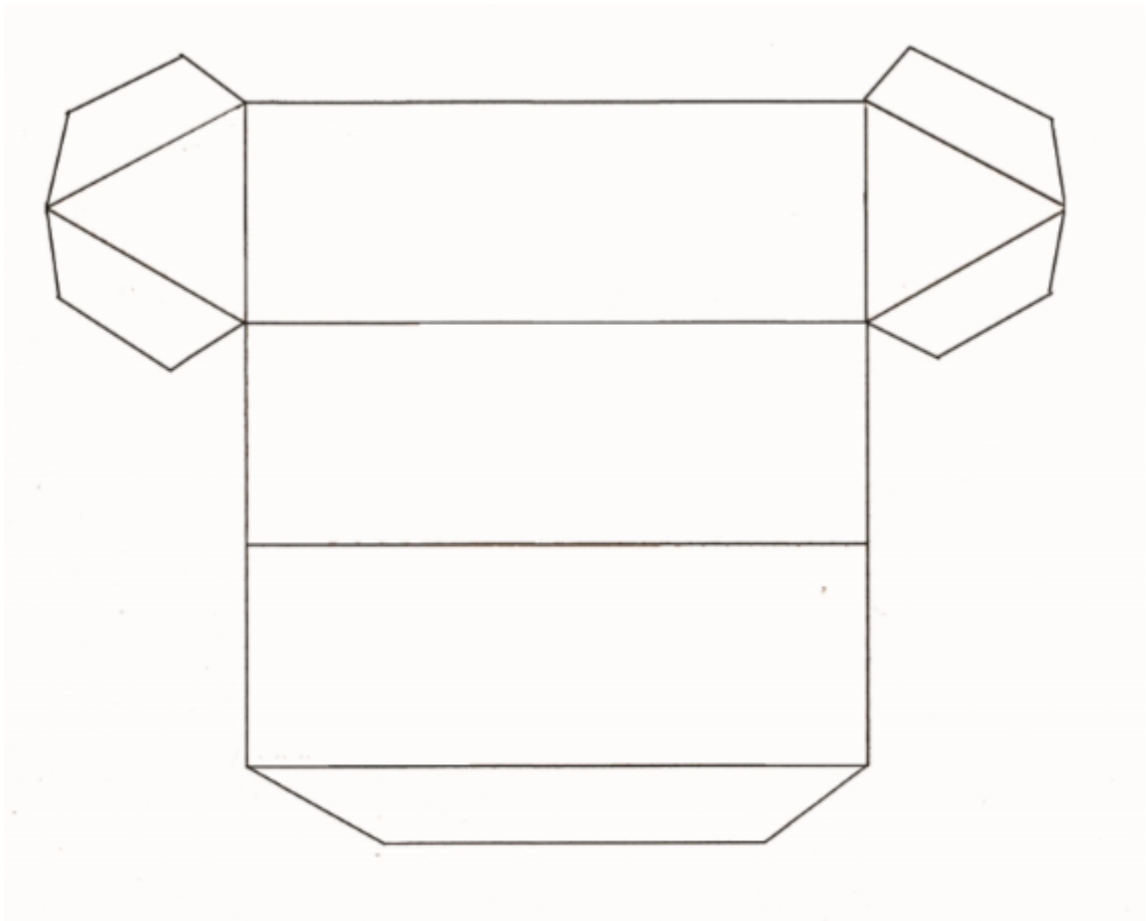



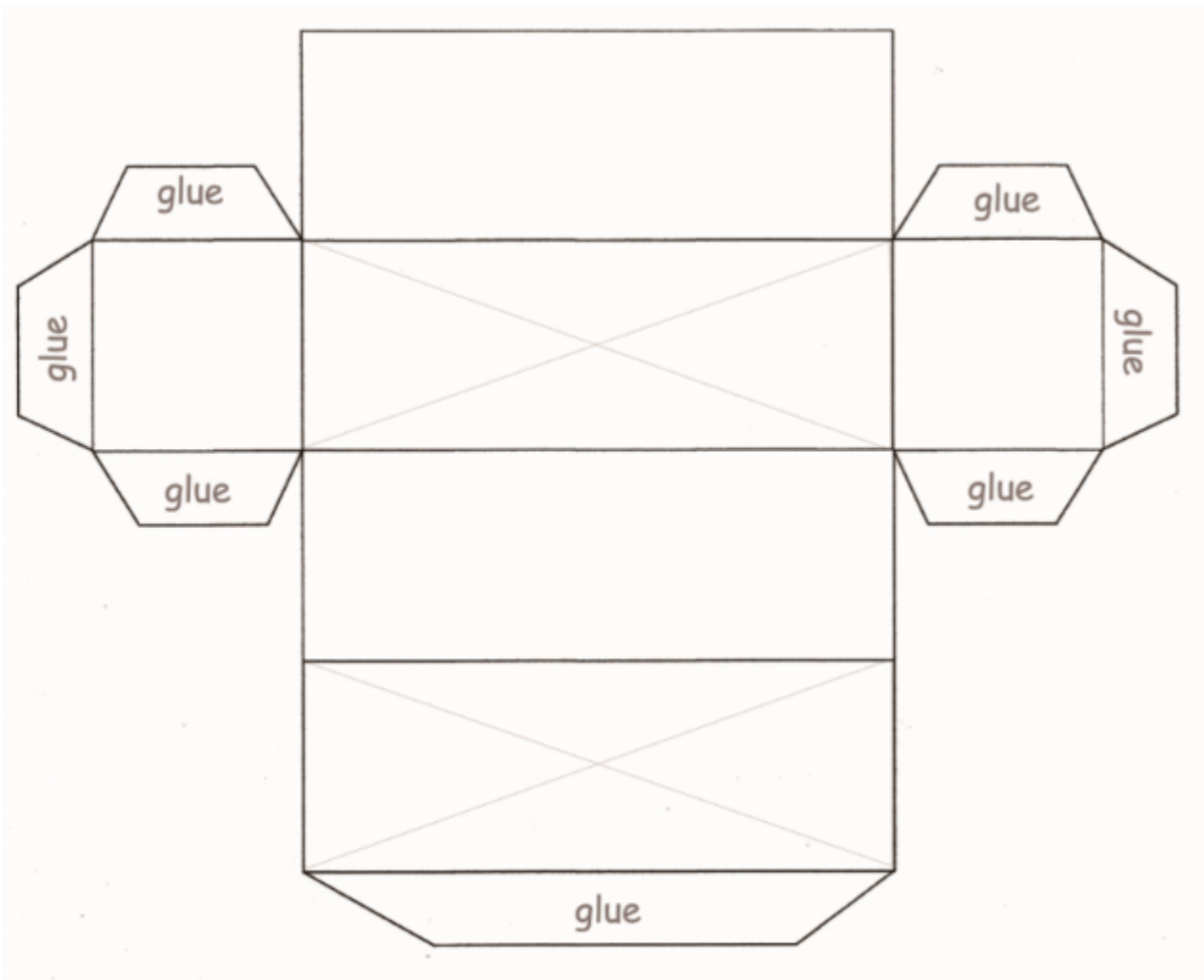
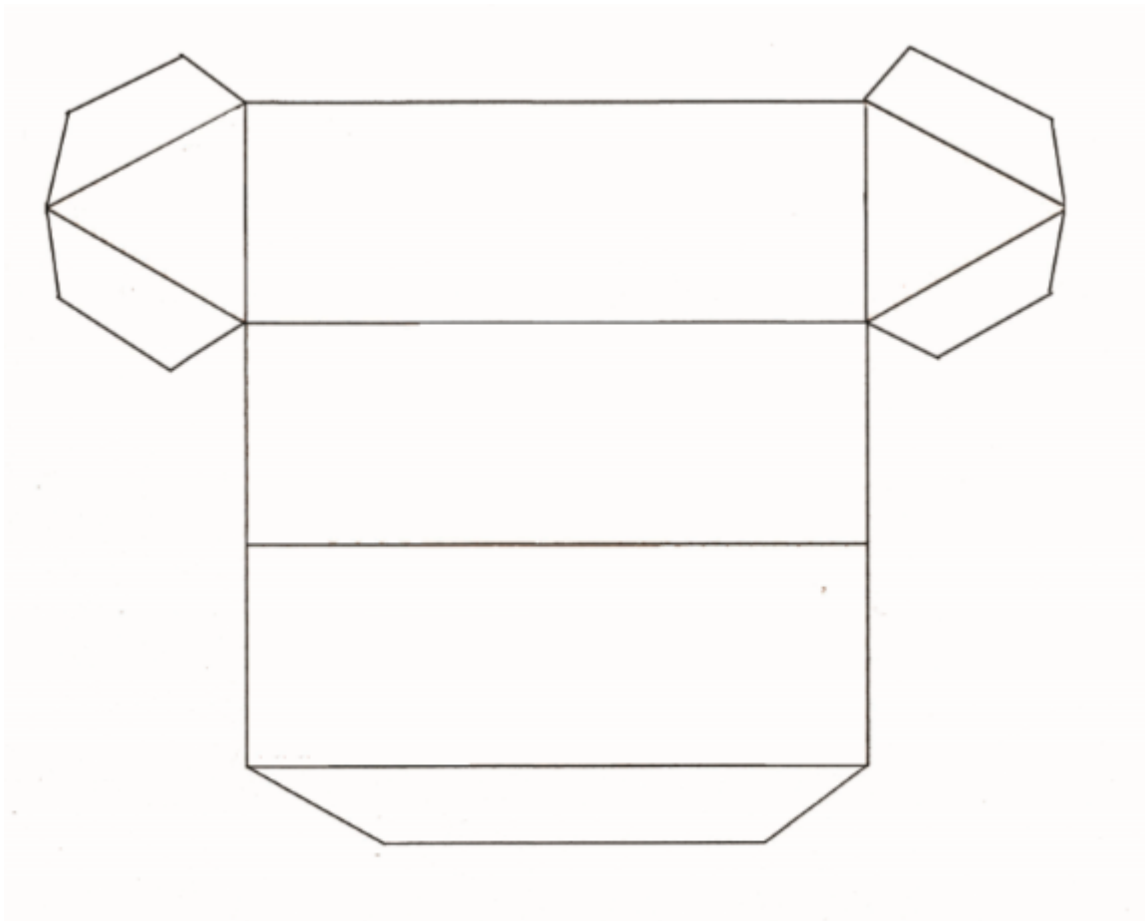

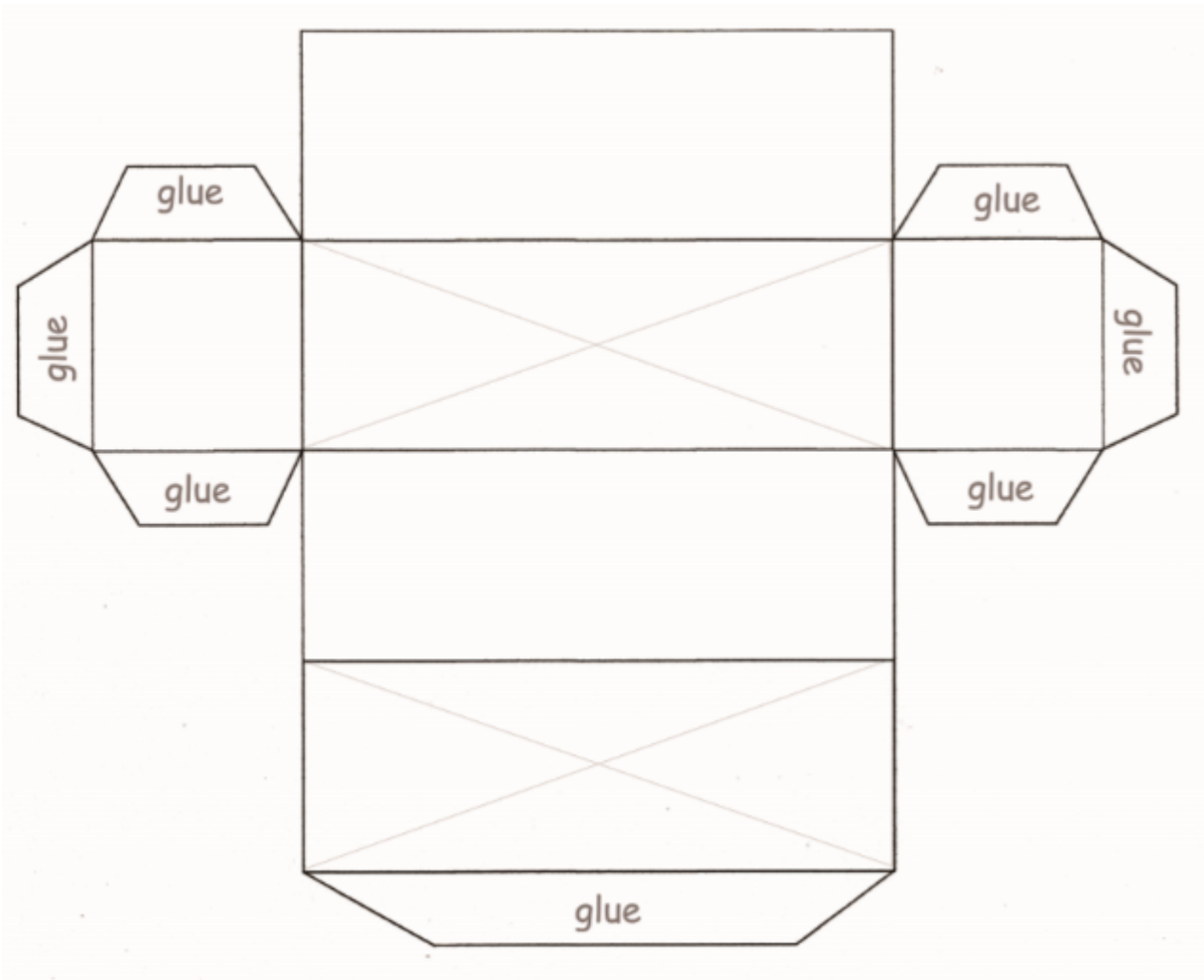
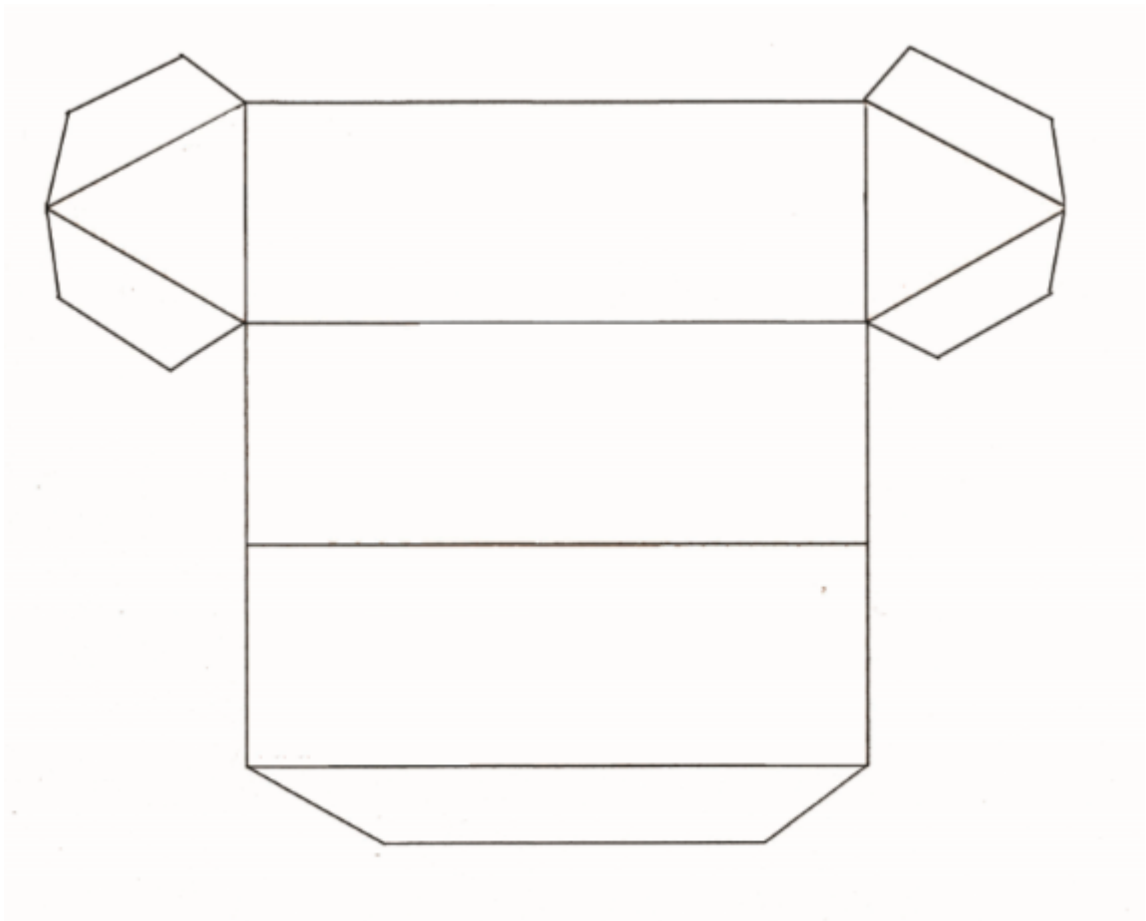





Date		
Subject/s	History	
Learning Objective	To know what towns and cities did to stop the plague	
		
	SA 	TA 
Success Criteria	I know that people were put into quarantine	
	I know people buried their loved ones or peo-	
	I know the different remedies that the plague	
Support	Independent	Adult Support ( )

What do we know about what Mompesson encouraged people to do to stop the plague from spreading?

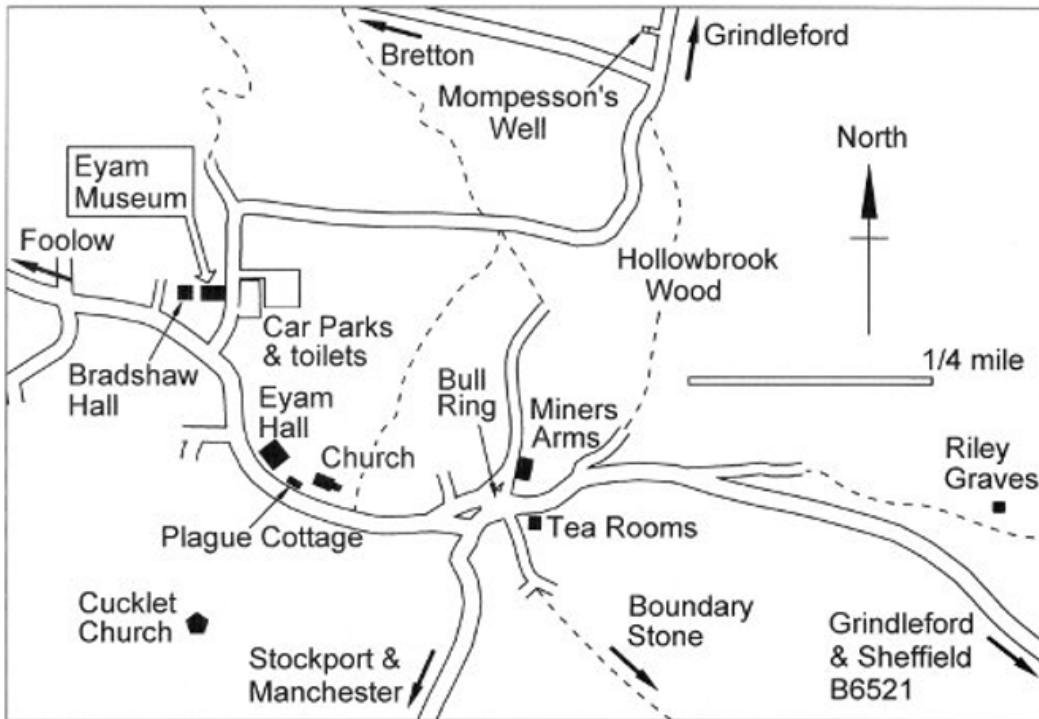

Look at this map. What do you notice about the church and the graves?

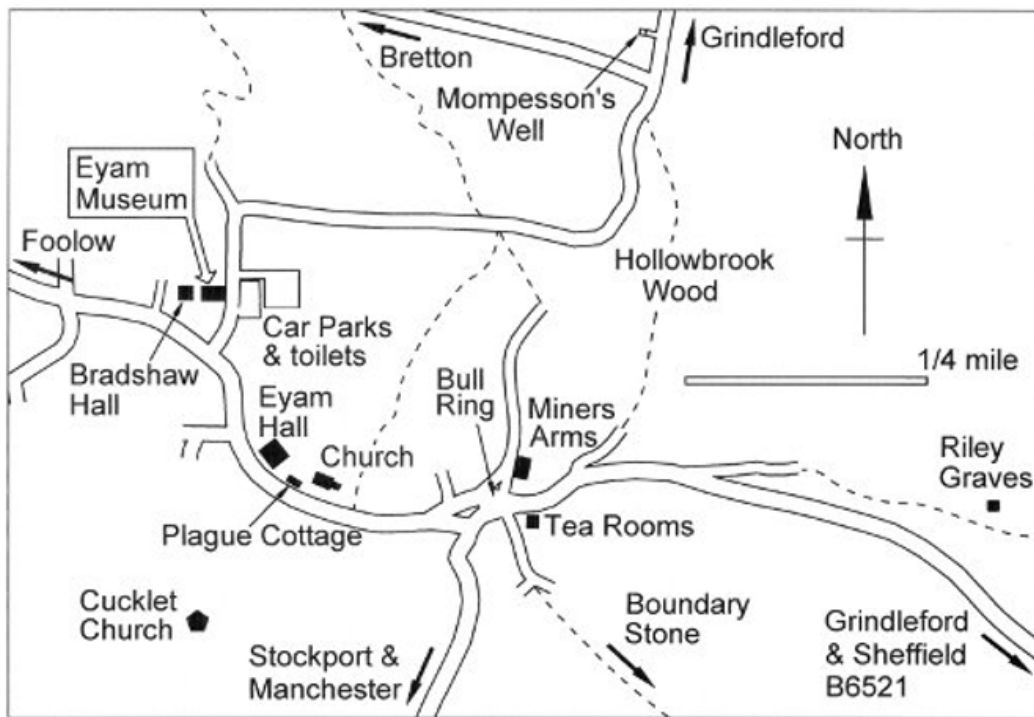

The church was closed off. Special measures were taken to try to stop the plague from spreading. In the first half of 1666, 200 people passed away. After the stonemason died, villagers had no choice but to engrave their own tombstones. Residents like Elizabeth Hancock buried their own dead, dragging bodies down the street by tying ropes around the victim's feet to avoid contact with the deceased. Church services were held in the open air to reduce the spread of disease, but by August 1666 the effects of the plague were devastating: 267 had been killed out of a population of 344.

# How did people try to stop the plague from spreading?

- 'Surgeons' were appointed, who examined the dead to establish the extent of the plague.
- Bills of Mortality were published, to publicise the course of the disease.
- 'Examiners' and 'searchers' were appointed, who established whether members of a household had contracted the plague. If so, they then shut up the house for a month, and its inhabitants had to stay indoors.
- Constables were appointed, who made sure no one left such houses.
- Bodies were buried at night in huge pits, and mourners were not allowed to attend.
- 'Pest houses' were set up, to quarantine sufferers.
- Householders were ordered to collect all waste, which was then removed by 'rakers'.
- Stray pigs, dogs, rabbits and cats were killed.

<https://www.bbc.com/education/guides/zd3wxnb/video>

## How did London try to cope?

Some new ideas were tried to tackle the plague.

**Plague doctors** cared for people, and nurses were hired to visit and record the sick.

**Watchmen** kept the sick in their houses so they did not spread the disease.

Houses where people were infected were marked with a red cross.

Dogs were suspected of carrying plague,

About 40,000 dogs and 80,000 cats were culled.

**Rakers** (cleaners) removed the sewerage and rubbish from the streets.



Think! Why might these actions be good for London?

# What Happened During the Plague?

The plague was horrible and could wipe out the population of a town within weeks.

By the end of 1665, 100 000 people had died in London.

When a household became infected the house was sealed which meant nobody could leave or enter the building. This meant the people would die.

Any houses where there was plague, were marked with a red cross on the front door, along with the words 'Lord have mercy on us'.



## Plague Doctor

### Plague Remedies

As the plague continued to stalk Europe, people invented strange remedies to try to cure it. Some of these cures used all sorts of peculiar ingredients that the desperate people were willing to try. They ranged from drinking fine wines or eating toads to bathing in milk. Many people believed that holding a small bunch of flowers and herbs up to the nose kept the plague away and even tobacco was highly valued as a medicine.

One of the most alarming images of the Great Plague is the clothing worn by the people who treated the plague victims.

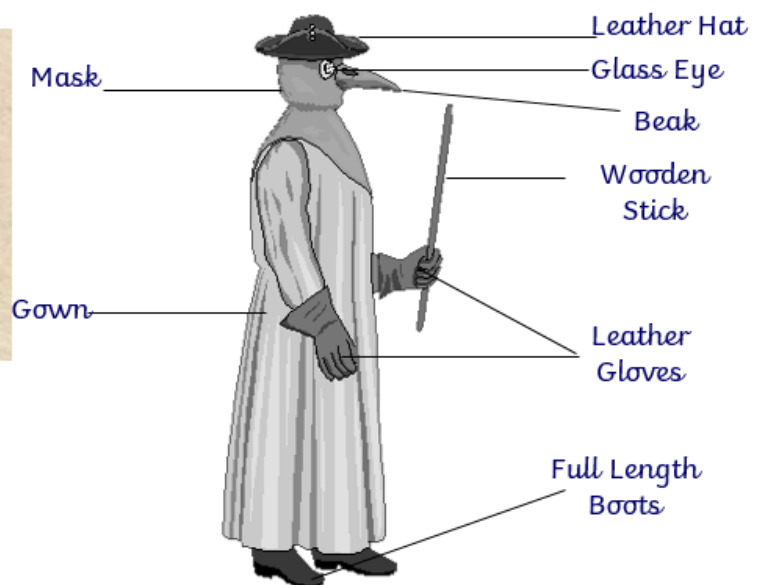

## The Plague Doctor

Many doctors, knowing that they could do nothing for plague victims, simply didn't bother trying to treat the disease. Those that did made sure that they were as protected as possible from the disease by wearing the 'uniform' shown above.

**Leather Hat** - The hat was made of leather. It was worn to show that the man was a doctor and also to add extra protection to the head.

**Beak** - The beak that was attached to the mask was stuffed with herbs, perfumes or spices to purify the air that the doctor breathed when he was close to victims.

**Glass Eye** - Glass eyes were built into the mask to make sure that the eyes were fully protected.

**Mask** - The mask covered the head completely and was gathered in at the neck for extra protection.

**Gown** - The full-length gown was made out of thick material which was then covered with wax. Undemeath the gown the doctor would wear leather breeches.

**Leather Gloves** - The doctor wore leather gloves to protect his hands from any form of contact with the disease.

**Wooden Stick** - The Plague Doctor carried a wooden stick so that he could drive people who came too close to him away.





Task

Write about the Plague Doctor. Draw and label the different things they wore and why.

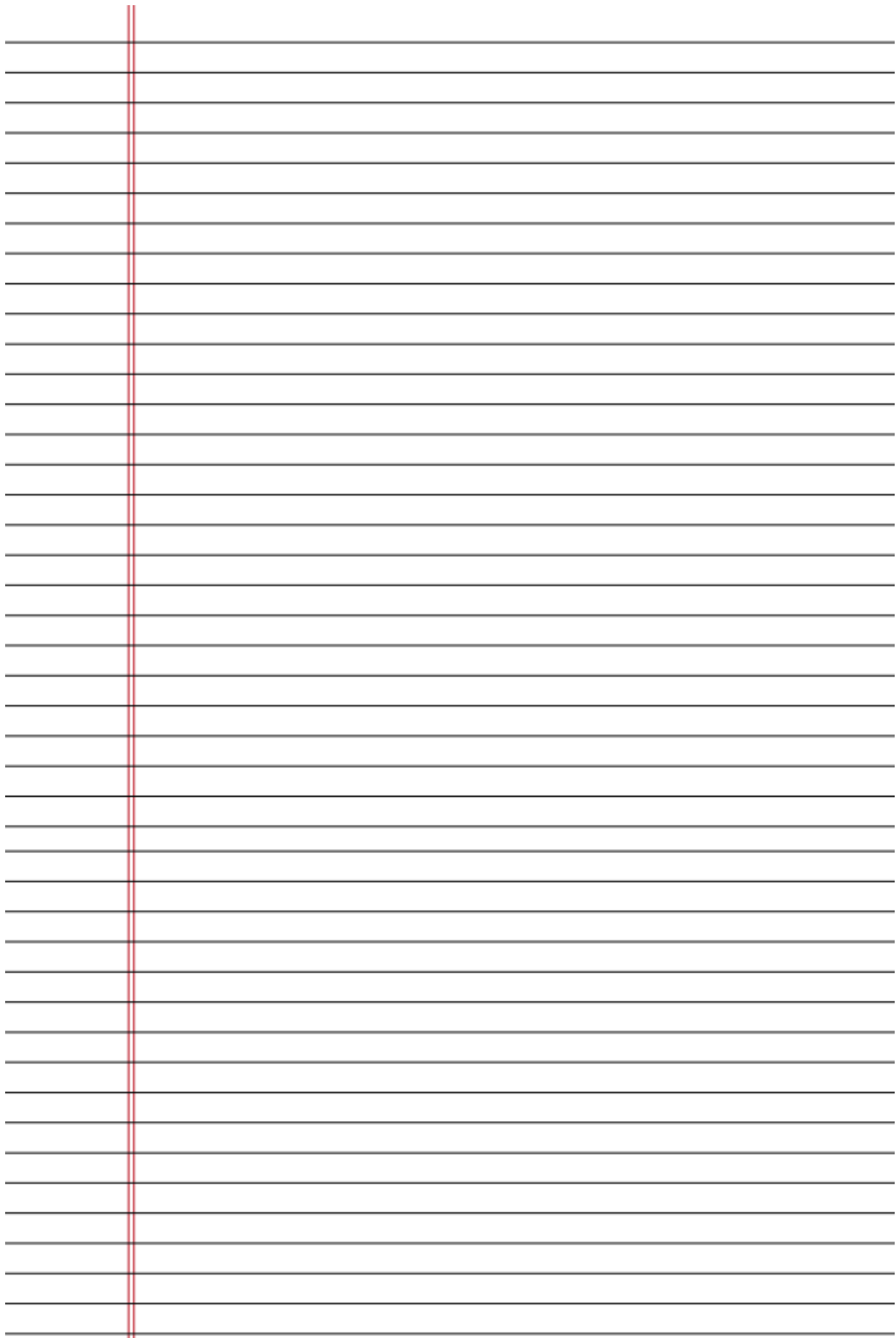





Date		
Subject/s	History	
Learning Objective	I know who reigned at the time of the plague	
	SA	TA
		
Success Criteria	I know King Charles II ruled as part of the Stuarts	
	I can explain what King Charles II did to prevent	
	I can write a fact file about King Charles' life	
Support	Independent	Adult Support ( )

The Great Plague 1665 began in London and spread to many cities (including Eyam).

1665 was in the era of 'The Stuarts.' The Stuarts (1603 – 1714) followed the Tudor (1485 – 1603) era.

During the time of the plague King Charles II reigned (1660 – 1685).

As the King, Charles demanded many different things that the people of London had to follow during the plague. Although the people of London had to follow the rules and hope to survive the plague, Charles left London until it was safe to return! He moved to Hampton Court and then to Oxford. He survived the plague and didn't die until 1685.

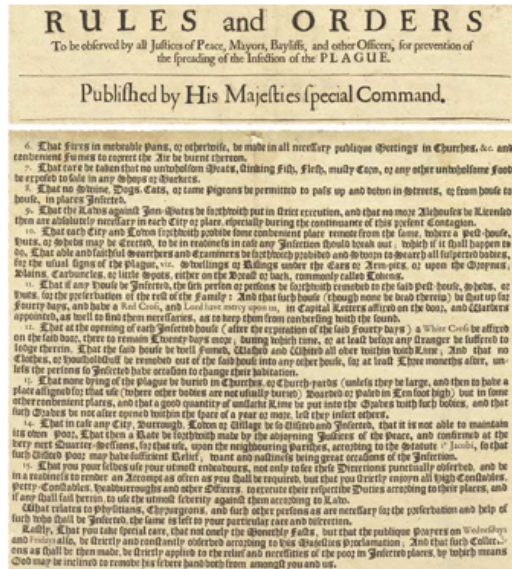

King Charles II



- 1.Charles II was born on 29 May 1630. He was the son of King Charles I and Henrietta Maria from France. Their first son, born about a year before Charles, had died aged less than a day.
- 2.Charles' mother, Henrietta, was the sister of King Louis XIII of France.
- 3.Charles II's father was beheaded in 1649. Charles I was the only English monarch to be executed by his own people.
- 4.Charles II was the third Stuart King of England.
- 5.Charles II spent much of his early adult life in France. After the civil war and the execution of his father, he did not dare to return to England.
- 6.Charles II was finally crowned as King of Scotland on 1 January 1661 in Scone and as King of England on 23 April at Westminster Abbey.
- 7.Charles II was known as the 'merry monarch'.
- 8.Charles II was a tall man, over 6 feet, and was said to be both calm in temperament and handsome!
- 9.Charles II married Catherine of Braganza, a Portuguese princess, in 1662. The couple never had children but the King wasn't a faithful husband. He had many affairs and had more than 12 illegitimate (a child born to parents not married to each other) children.
- 10.Charles II died on 6 February 1685. He was 54 years old.

# King Charles II

- Charles II was monarch of the three kingdoms of England, Scotland and Ireland.
- Charles II brought peace to the people of England. Christmas was celebrated again and theatres were reopened.
- Charles II promised to punish the men responsible for his father's death and was true to his word. He had the bodies of Oliver Cromwell, Henry Ireton, Thomas Pride and John Bradshaw dug up and they were hung at Tyburn. Oliver Cromwell's body was beheaded and his head was stuck on a pike at London Bridge after it was paraded through the streets of the capital.
- Charles II liked to spend! He became known for spending huge amounts of money and was responsible for leaving the bank accounts of England rather empty.
- Charles II was a Catholic at heart and during his reign he tried to relax the laws against the Catholics. He lived his life as a Protestant, however, and only converted to Catholicism on his deathbed as he didn't think the people would have welcomed a Catholic King.
- Charles II was a big dog lover and had a toy spaniel he was very fond of – so much so that he played with the dog during council meetings!
- The breed of dog became hugely popular after the King showed such an interest and was as a consequence named after him: the King Charles Spaniel.
- Charles II showed his bravery when the Great Fire of London broke out in 1666. He got involved in helping to tackle the fire himself, putting his own life at risk.
- Charles was a very experienced rider and not only liked to visit Newmarket races but often raced horses himself there too!
- Charles II's wife, Catherine of Braganza, introduced tea drinking to England.

## Task

Use the information above, along with research from the internet, to write a biography about King Charles II.

Look at the biography example and checklist to support you with your own writing.

# J.K. Rowling Fact File

## Biography

Going from unemployment to being a multi-millionaire in the space of 5 years, J.K. Rowling's story is almost as amazing as Harry Potter's! She is the best-selling living author in the UK and her books are popular all over the world. Rowling has described writers such as Jane Austen and C.S. Lewis as her sources of inspiration.

She was born Joanne Rowling on 31st July 1965, in Gloucestershire. She enjoyed writing fantasy stories from an early age, reading them to her younger sister. As a teenager, Rowling began studying French and Classics at Exeter University. Having graduated, she moved to London to work as a researcher for Amnesty International, an organisation which works to protect human rights around the world. She later moved to Manchester, where she worked at the Chamber of Commerce.

It was in 1990, when Joanne was on a delayed train journey from Manchester to London that the idea for a series of books came into her head. During the writing of the first Harry Potter book, Joanne's mother died, greatly affecting her writing.

Rowling decided to introduce more detail about the loss of the main character's parents as she knew how it felt. Rowling used her life as inspiration for many other ideas in the book, for example, her parents met at Kings Cross Station, which is where Harry Potter catches the train to school, and Joanne shares her birthday with Harry.

After living and working as an English teacher in Portugal, Rowling moved to Edinburgh with her daughter, who is named after one of Joanne's favourite writers. Those early days of living in Scotland weren't easy for Rowling - she had no job but dedicated her time to finishing her book. When the story was finally completed, it was sent to 12 different publishing houses, all of which turned it down. In 1997, the book was finally published by Bloomsbury under the name J.K. Rowling. As Joanne didn't have a middle name, she incorporated her grandmother's

**Name:**

Joanne Rowling

**Born:**

31st July 1965

**Place of birth:**

Gloucestershire, UK

**Occupation:**

Writer, Author



Photo courtesy of SJHil - granted under creative commons licence

name, 'Kathleen' into her initials. Her real name wasn't used as the publishers didn't think that boys would want to read a book written by a female author. Shortly after being published, the book won its first award and proved to be hugely popular. She later released the sequel, 'Harry Potter and the Chamber of Secrets', followed by 'Harry Potter and the Prisoner of Azkaban'. It was the fourth book in the series, 'Harry Potter and the Goblet of Fire', which broke sales records in both the UK and America. Rowling was also named Author of the Year at the 2000 British Book Awards and awarded an OBE for services to children's literature.

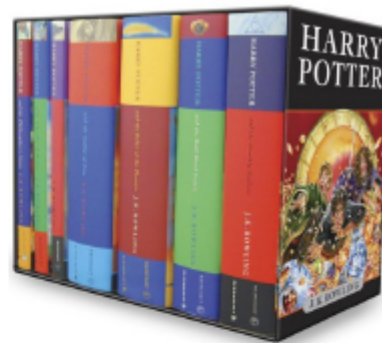

Photo courtesy of veganstraightedge @flickr - granted under creative commons licence

The final book in the series, 'Harry Potter and the Deathly Hallows', was released in 2007 and became the fastest-selling book in history, selling millions of copies on the first day of release. The books were made into hugely successful films and have captured the imaginations of children and adults all around the world. Since the end of the Harry Potter stories, Rowling has written other books linked to the series. She has also written stories for adults and continues to embark on other projects.

Today, original copies of 'Harry Potter and the Philosopher's Stone' sell for around £20,000 and the series has been translated into 65 languages.

### Have I...



used a question or interesting opening statement to hook the reader?	
summarised the main events of the person's life in the first paragraph?	
written in the past tense?	
used third person pronouns?	
written about key events in the person's life?	
written about key influences in the person's life?	
used the passive voice?	

linked sentences and paragraphs using:

• ellipsis?	
• repetition?	
• adverbials?	

summarised the person's life by mentioning:

• their main achievements?	
• personality?	
• how he or she will be remembered?	

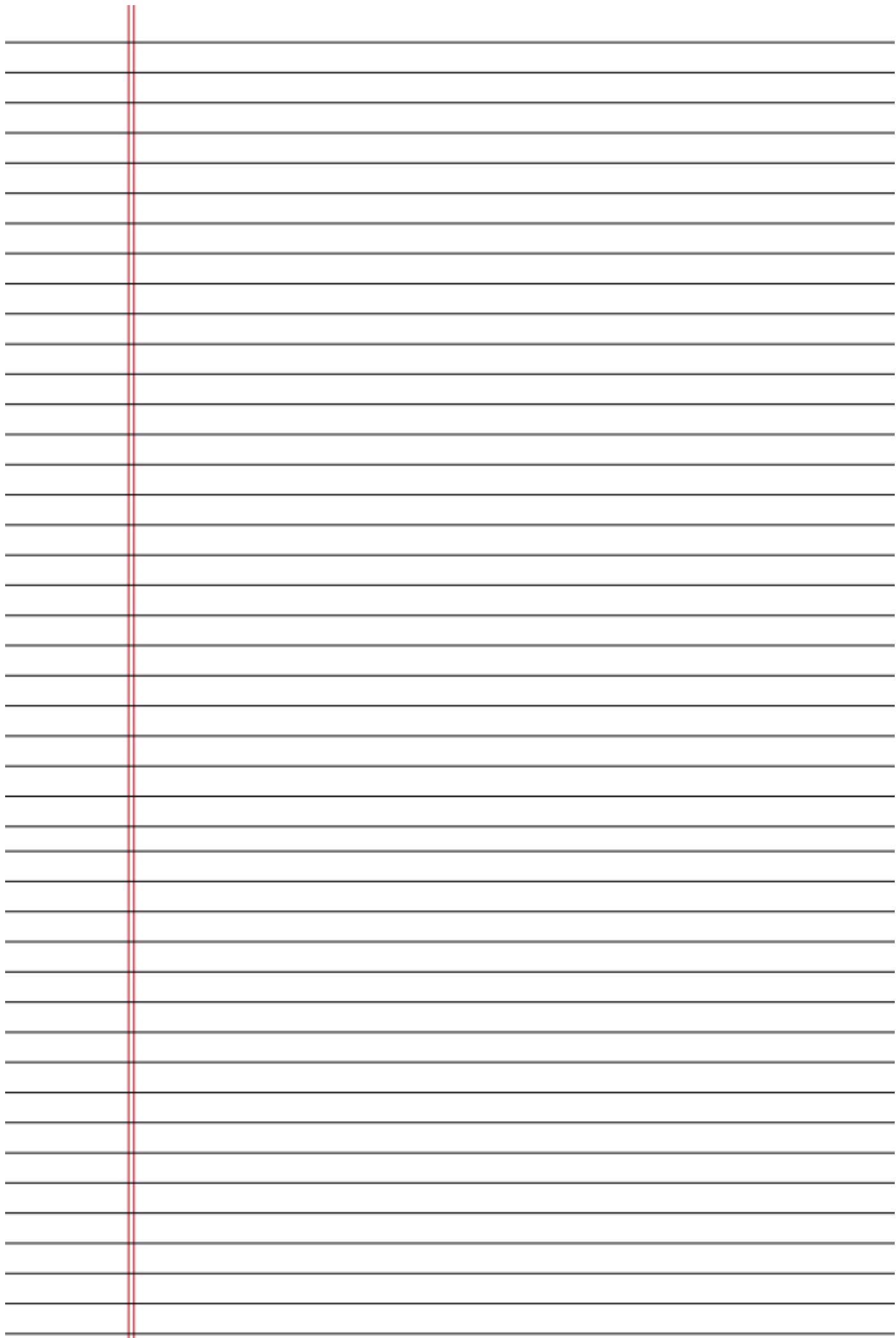

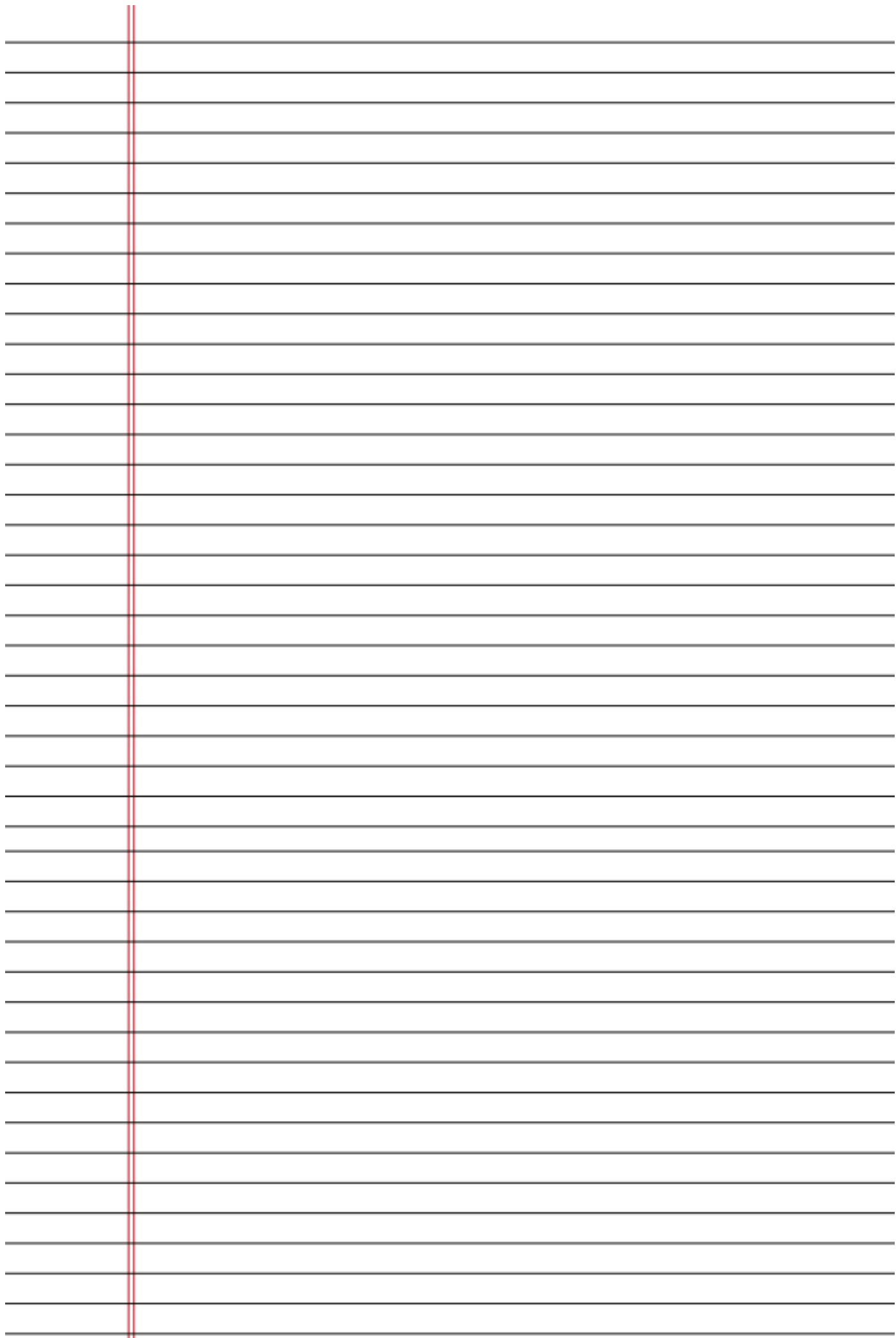

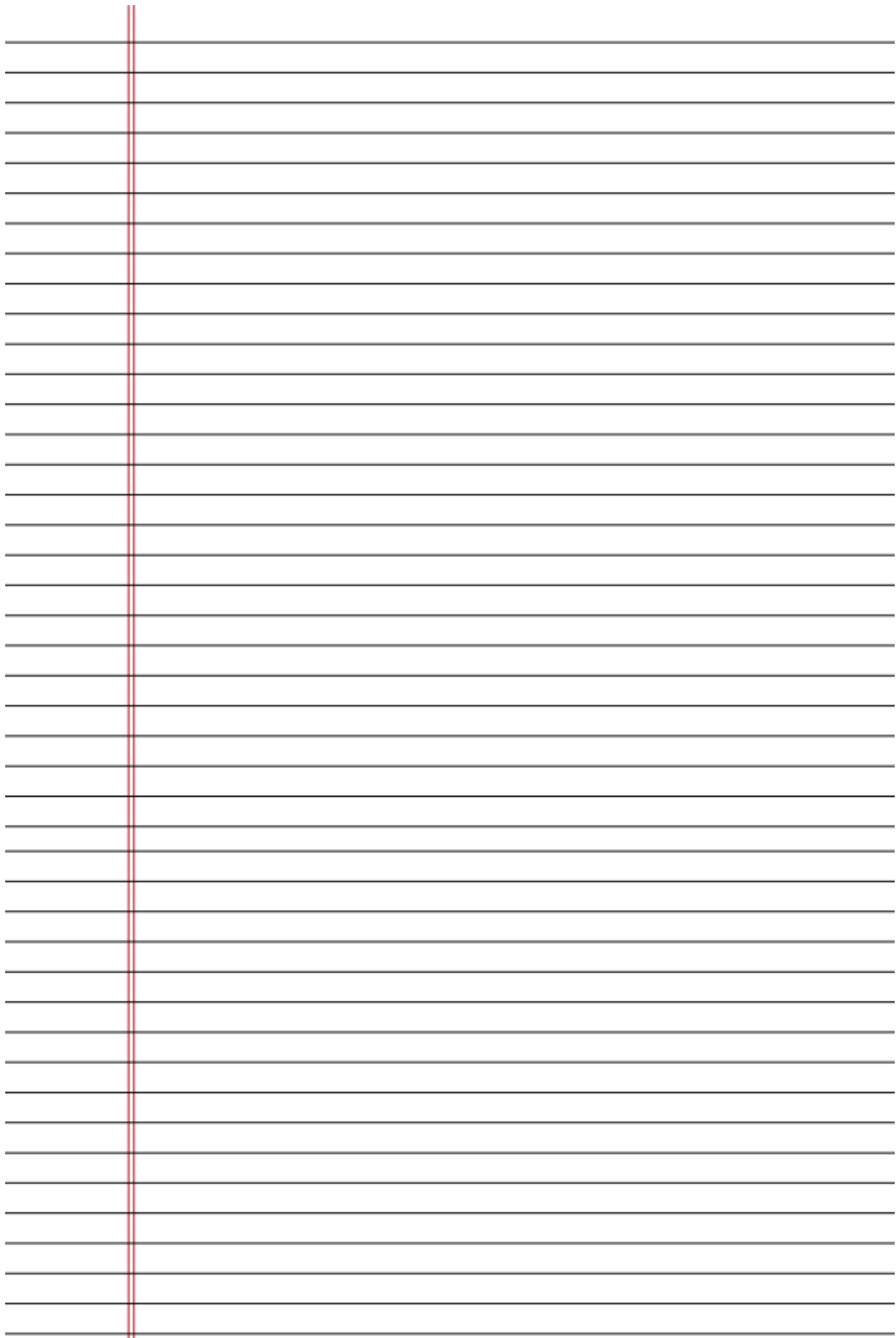

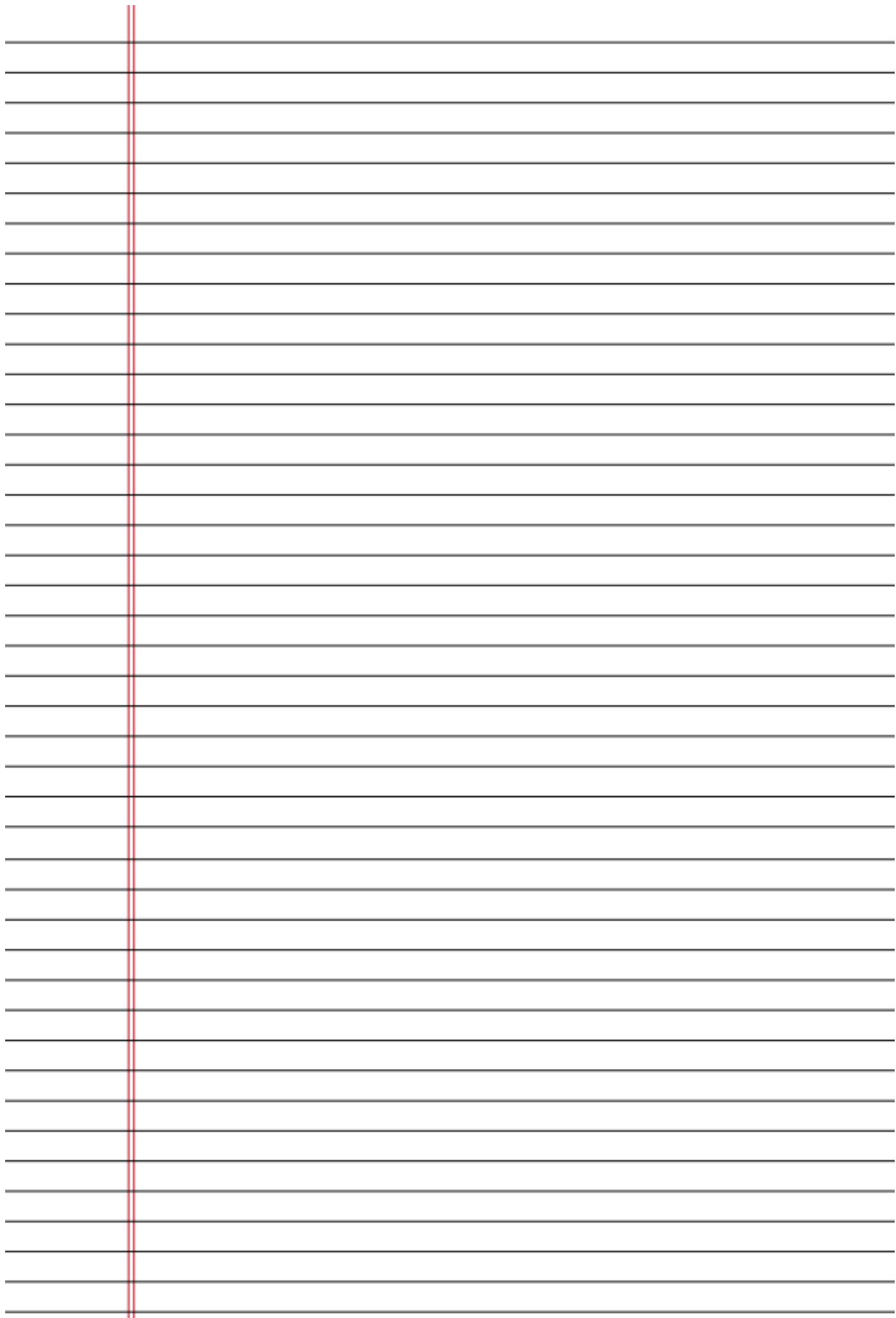





Date		
Subject/s	History	
Learning Objective	I can discuss how the plague effected people's daily lives	
	SA 	TA 
Success Criteria 	I know Samuel Pepys was an important figure in learning about the plague because of his diary	
	I can discuss what people's opinions and feelings might have been at the time of the plague	
	I can write a diary using my knowledge of	
Support	Independent	Adult Support ( )
<p>In your diary include:</p> <ul style="list-style-type: none"> <li>What London was like</li> <li>What they thought caused the plague</li> <li>Symptoms</li> <li>The ways they tried to stop the spread (the plague doctor and watch men)</li> <li>Thoughts and feelings</li> <li>Lost family members</li> </ul>		

# The devastation of the Plague

1665 was London's worse epidemic about 100,000 people died.  
 In the third week of September, 8,297 official plague deaths were reported.



# Who was Samuel Pepys?

- Samuel Pepys worked for the British government and navy and lived during the 17th Century.
- He is most famous for writing a diary between 1659 and 1669.
- Today, we use his diary as a historical record of the events of the past.



## The Life of Samuel Pepys

- Samuel Pepys was born in London on 23rd February 1633.
- His father was a tailor and his mother was a butcher's daughter.
- He went to St Paul's School in London and later went to Cambridge University.
- After university, he began working for the government and the navy. His cousin, the Earl of Sandwich, helped him to get a good job.
- Samuel Pepys married a young French girl named Elizabeth in 1655.
- Samuel Pepys enjoyed music and played several instruments during his life.
- He also liked going to the theatre, wearing fine clothes and a wig! Many rich men did this.

## The Diary

Samuel Pepys began writing his diary on 1st January 1660.

He wrote of everyday things that happened in his life but also about important events in Britain's history.

Pepys wrote with quills and ink – there were no ball point pens in those days!

He wrote using a secret code, a shortened version of words. He did this because he didn't want people he knew, including his wife Elizabeth, to read his diary.

# Extract from Samuel Pepys' diary

- 16 October 1665  
But Lord, how empty the streets are, so many poor sick people in the streets, full of sores, and so many sad stories overheard as I walk, everybody talking of this dead, and that man sick, and so many in this place.



How useful is this source for a historian?

## The Great Plague

Pepys lived through the Great Plague that spread through London in 1665 and wrote about it in his diary.

If a person was suffering with the Plague, also known as the Black Death, they would have some of these symptoms:

- Fever
- A 'Ring-σ'-Roses' which is a circle of spots
- Sneezing
- The plague would usually lead to death

People didn't know very much about how the Plague spread and some thought it was carried by stray cats and dogs. As a result many animals were killed. Some thought it was in the air so they held bunches of posies to their noses to smell instead of the air. Fleas on black rats are what actually caused the disease to spread.

Ring-σ'-Roses is a famous nursery rhyme about people suffering from the Great Plague.

## The Great Fire

- Pepys also wrote about the Great Fire of London a year later in 1666.
- On 2nd September 1666, a fire broke out at Thomas Farriner's bakery on Pudding Lane.
- In those days, houses in London were made out of wood and were built very close together. It was easy for the fire to spread.
- The fire burned for 4 days and more than 13, 000 houses were destroyed. Sadly, around 16 people lost their lives. Luckily, most people were able to escape the fire.



# The Great Fire

- Pepys recorded the ways people escaped the fire. He watched them escape in boats on the River Thames because the fire could not spread along the water. When he felt he was in danger, he buried a parmesan cheese from Italy because it was expensive.
- In those days, fire fighters were not as well equipped as they are today. There were no fire engines, instead they used horse-drawn carts and leather buckets. They had no gas masks or protective clothing so they were in danger of catching fire if they entered a burning building.

## Your Task

Imagine that you were alive when the Plague hit London in 1665. You must write a diary entry describing what it was like in Plague ridden London.

You must write about

- What London was like..
- What they thought caused the Plague...
- Symptoms of the Plague..
- The ways they tried to stop the spread (the Plague doctor and watch men)
- The devastation of the Plague...

Paragraph

Key Information

Feelings/emotions

Introduction

Paragraph 1

Paragraph 2

Paragraph 3

Ending

